

# FRONT END CYLINDER

TYPE : MF-RP

SERIE : Ø 165

CYL.TYPE

MF 165.5.6375 RP - D.1595

For Tipping Weight See Advices Below

## Technical Characteristics

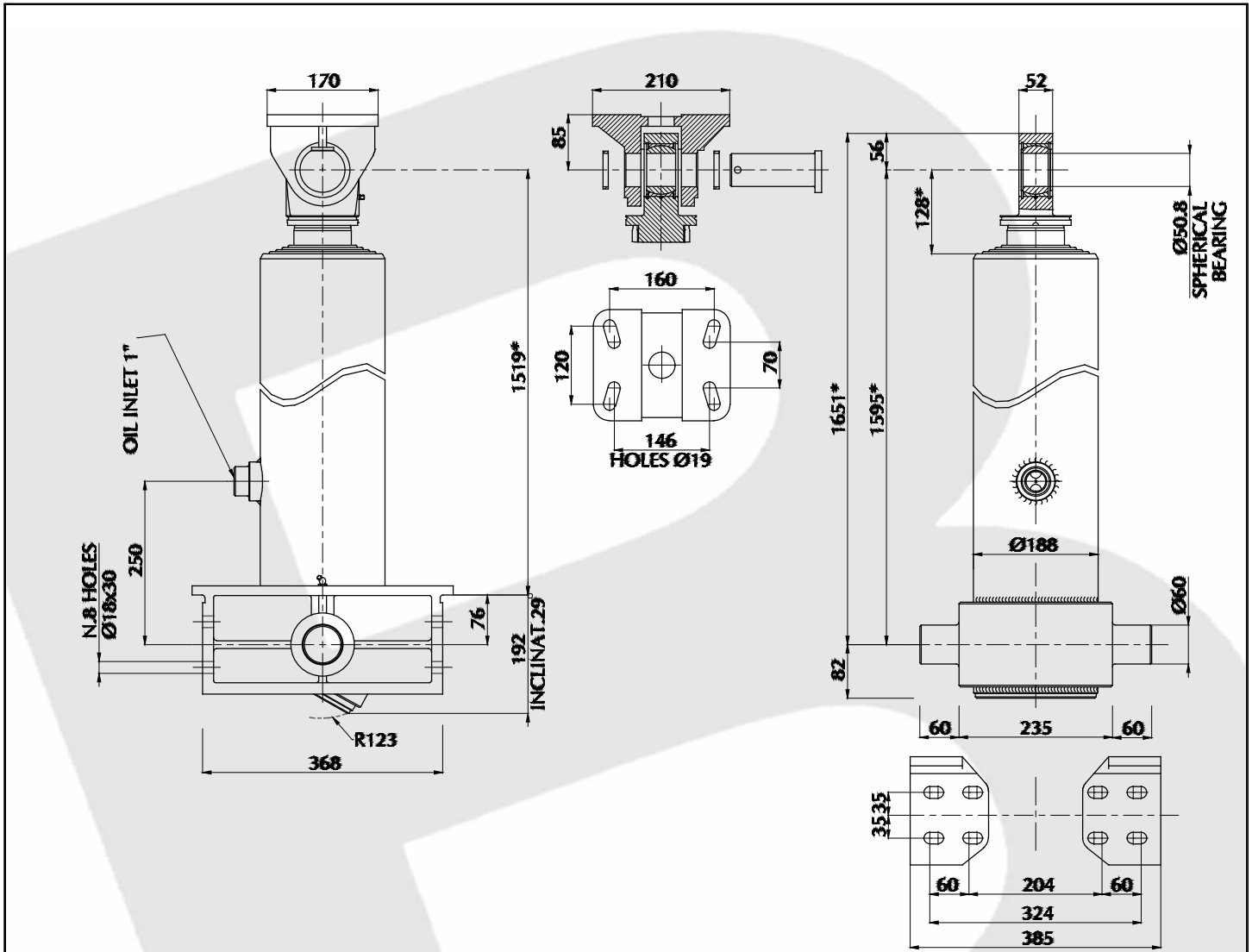

## Cylinder stages

Ø Stage	Ø045	Ø060	Ø076	Ø092	Ø108	Ø069	Ø088	Ø107	Ø126	Ø145	Ø165	Ø167	Ø187	Ø210	Ø236	Ø265
Thrust at 200 Bar [Tons]	---	---	---	---	---	---	12.20	18.00	24.90	33.00	42.80	---	---	---	---	---
Stages of cylinder							●	●	●	●	●					

## Specifications

Stages number	05
Cylinder Stroke [ mm ]	6375
Cylinder weight only [ Kgs ]	251
Working volume [ Ltrs ]	83.4
Max Working pressure [ Bar ]	200

## Technical information

<input type="checkbox"/> Oil	: See oil specification sheet
<input type="checkbox"/> Tipping weight	: Net weight body + Payload
<input type="checkbox"/> Fitted centres [°]	: Closed centres plus 20 mm pull out

## Advices

All our cylinders are manufactured to suit the particular application in the differing world markets/climate. Should you require details of the exact lifting capacity of the cylinder that has been selected for your application/vehicle then please contact our technical department who will be only pleased to explain or advise.

## Brackets and Accessories

Chassis bracket [ 2 Units x cylinder]	SIL#MIH	15.48 [ Kgs ] x 2 =
Lifting bracket	SSL#PFH	11.75 [ Kgs ] x 1 =
Chassis brackets mounting kit	KFSI#001	

## Recommendation

<input type="checkbox"/> This Binotto cylinder is designed as a lifting device only
<input type="checkbox"/> It must not be used as a structural member or be subject to side loads
<input type="checkbox"/> Pump flow in consultation with Binotto engineering department

## BINOTTO SRL

BINOTTO IS CONSTANTLY ENGAGED IN IMPROVING ITS PRODUCTS AND THEREFORE RESERVES THE RIGHT TO MODIFY WITHOUT ANY NOTICE CHARACTERISTICS SHOWN

VIA DIVISIONE JULIA, 7/B - 36031 DUEVILLE (VI) ITALY • TEL. 0039.0444.593290 - FAX. 0039.0444.593357 • E-MAIL. INFO@BINOTTO.COM

Edit.: 04 • 2006

Rev.: 01 • 2006

Date: 01.09.2006

Pag.: MF-RP 165.5.6375\_02